

ECO.60s+

Magnetic drilling machine

EUROBOOR

FOR PROFESSIONALS BY PROFESSIONALS

Technical data

	Metric	Imperial
Annular cutting	Ø 12 - 60 mm	Ø 1/2" - 2 3/8"
Twist drilling	Ø 1 - 23 mm	Ø 1/16" - 15/16"
Countersinking	Ø 10 - 65 mm	Ø 3/8" - 2 9/16"
Length	320 mm	12 5/8"
Width	200 mm	7 7/8"
Height max.	452 - 622 mm	17 13/16" - 24 1/2"
Stroke	170 mm	6 11/16"
Weight*	12.9 kg	28.4 lbs
Magnet (l x w x h)	168 x 84 x 49 mm	6 5/8" x 3 5/16" x 1 5/16"
Magnetic force	1,850 kg	4,080 lbs
Motor power	1,600 W	14.5 A
Total power	1,700 W	15.4 A
Speed		(I) 60 - 275 rpm
(no load)		(II) 100 - 500 rpm
Speed		(I) 60 - 275 rpm
(load 1,600 W, 14.5 A)		(II) 100 - 500 rpm
Spindle (Weldon)	MT3 19.05 mm	MT3 3/4"
Voltage		110 - 120 V / 60 Hz
		220 - 240 V / 50 - 60 Hz

* Without power cord and handles

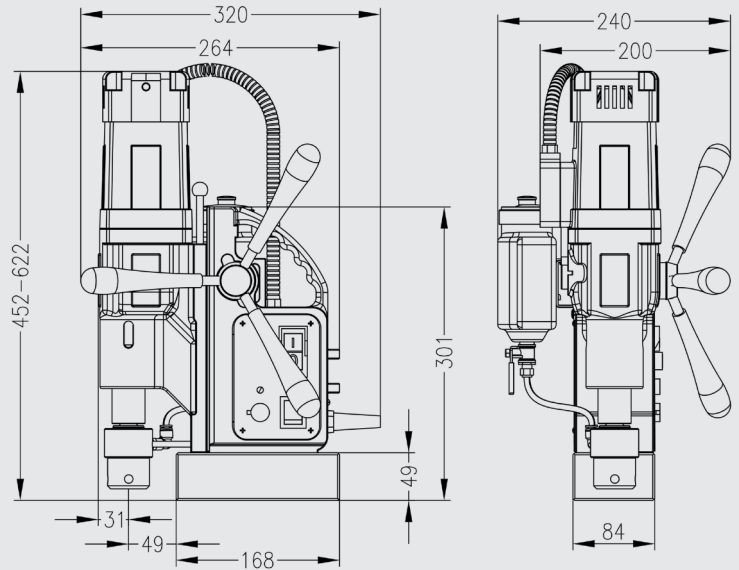

Features

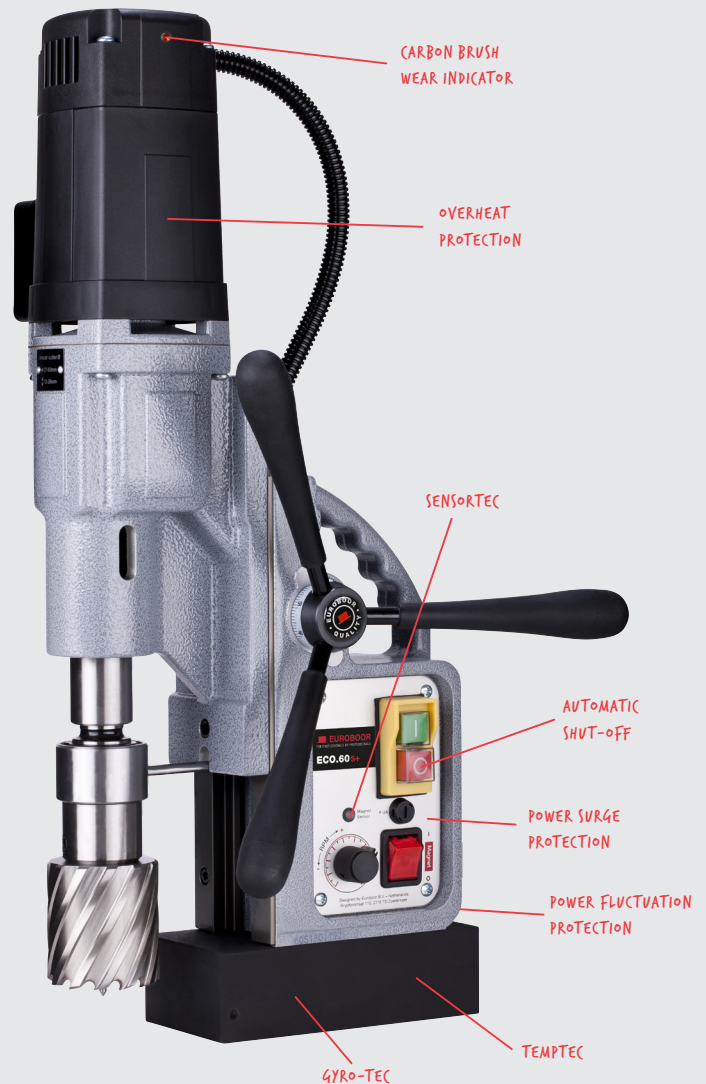
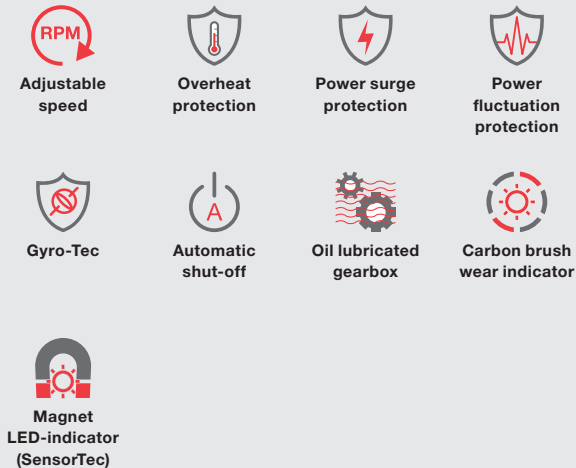

Euroboor makes every effort to meet quality and integrity requirements. That is why we as an organization are proud of the recognition of some leading organizations worldwide:



www.euroboor.com